

SOLUTIONS & ANSWERS FOR JEE MAINS-2025
29th January Shift 1

MATHEMATICS

SECTION-A

Q.1 Let the area of the region $\{(x, y) : 2y \leq x^2 + 3, y + |x| \leq 3, y \geq |x - 1|\}$ be A. Then 6A is equal to :

- Options 1. 16
2. 12
3. 18
4. 14

Key : (4) 14

Q.2 Let the ellipse $E_1 : \frac{x^2}{a^2} + \frac{y^2}{b^2} = 1, a > b$ and $E_2 : \frac{x^2}{A^2} + \frac{y^2}{B^2} = 1, A < B$ have same eccentricity $\frac{1}{\sqrt{3}}$. Let the product of their lengths of latus rectums be $\frac{32}{\sqrt{3}}$, and the distance between the foci of E_1 be 4. If E_1 and E_2 meet at A, B, C and D, then the area of the quadrilateral ABCD equals :

- Options 1. $\frac{12\sqrt{6}}{5}$
2. $\frac{18\sqrt{6}}{5}$
3. $6\sqrt{6}$
4. $\frac{24\sqrt{6}}{5}$

Key : (4) $\frac{24\sqrt{6}}{5}$

Q.3 Let M and m respectively be the maximum and the minimum values of

$$f(x) = \begin{vmatrix} 1 + \sin^2 x & \cos^2 x & 4 \sin 4x \\ \sin^2 x & 1 + \cos^2 x & 4 \sin 4x \\ \sin^2 x & \cos^2 x & 1 + 4 \sin 4x \end{vmatrix}, x \in \mathbb{R}$$

Then $M^4 - m^4$ is equal to :

- Options 1. 1295
2. 1215
3. 1040
4. 1280

Key : (4) 1280

Q.4

Define a relation R on the interval $\left[0, \frac{\pi}{2}\right)$ by $x R y$ if and only if $\sec^2 x - \tan^2 y = 1$. Then R is :

- Options 1. both reflexive and symmetric but not transitive
2. an equivalence relation
3. reflexive but neither symmetric nor transitive
4. both reflexive and transitive but not symmetric

Key : (2) an equivalence relation

Q.5

The integral $80 \int_0^{\frac{\pi}{4}} \left(\frac{\sin \theta + \cos \theta}{9 + 16 \sin 2\theta} \right) d\theta$ is equal to :

- Options 1. $6 \log_e 4$
2. $4 \log_e 3$
3. $2 \log_e 3$
4. $3 \log_e 4$

Key : (2) $4 \log_e 3$

Q.6 The least value of n for which the number of integral terms in the Binomial expansion of $(\sqrt[3]{7} + \sqrt[12]{11})^n$ is 183, is :

- Options 1. 2184
2. 2172
3. 2148
4. 2196

Key : (1) 2184

Q.7 Let $y = y(x)$ be the solution of the differential equation

$\cos x (\log_e(\cos x))^2 dy + (\sin x - 3y \sin x \log_e(\cos x)) dx = 0$, $x \in \left(0, \frac{\pi}{2}\right)$. If $y\left(\frac{\pi}{4}\right) = \frac{-1}{\log_e 2}$, then $y\left(\frac{\pi}{6}\right)$ is equal to :

- Options 1. $\frac{1}{\log_e(3) - \log_e(4)}$
2. $\frac{1}{\log_e(4) - \log_e(3)}$
3. $-\frac{1}{\log_e(4)}$
4. $\frac{2}{\log_e(3) - \log_e(4)}$

Key : (1) $\frac{1}{\log_e(3) - \log_e(4)}$

Q.8 Let $A = [a_{ij}] = \begin{bmatrix} \log_5 128 & \log_4 5 \\ \log_5 8 & \log_4 25 \end{bmatrix}$.

If A_{ij} is the cofactor of a_{ij} , $C_{ij} = \sum_{k=1}^2 a_{ik} A_{jk}$, $1 \leq i, j \leq 2$, and $C = [C_{ij}]$, then $8|C|$ is equal to :

- Options 1. 262
2. 288
3. 242
4. 222

Key : (3) 242

Q.9 Let ABC be a triangle formed by the lines $7x - 6y + 3 = 0$, $x + 2y - 31 = 0$ and $9x - 2y - 19 = 0$. Let the point (h, k) be the image of the centroid of ΔABC in the line $3x + 6y - 53 = 0$. Then $h^2 + k^2 + hk$ is equal to :

- Options 1. 47
2. 40
3. 36
4. 37

Key : (4) 37

Q.10 Two parabolas have the same focus $(4, 3)$ and their directrices are the x -axis and the y -axis, respectively. If these parabolas intersect at the points A and B, then $(AB)^2$ is equal to :

- Options 1. 392
2. 384
3. 96
4. 192

Key : (4) 192

Q.11 Let $\vec{a} = \hat{i} + 2\hat{j} + \hat{k}$ and $\vec{b} = 2\hat{i} + 7\hat{j} + 3\hat{k}$. Let $L_1: \vec{r} = (-\hat{i} + 2\hat{j} + \hat{k}) + \lambda\vec{a}$, $\lambda \in \mathbf{R}$ and

$L_2: \vec{r} = (\hat{j} + \hat{k}) + \mu\vec{b}$, $\mu \in \mathbf{R}$ be two lines. If the line L_3 passes through the point of intersection of L_1

and L_2 , and is parallel to $\vec{a} + \vec{b}$, then L_3 passes through the point :

- Options 1. $(8, 26, 12)$
2. $(2, 8, 5)$
3. $(5, 17, 4)$
4. $(-1, -1, 1)$

Key : (1) $(8, 26, 12)$

Q.12 Let P be the set of seven digit numbers with sum of their digits equal to 11. If the numbers in P are formed by using the digits 1, 2 and 3 only, then the number of elements in the set P is :

- Options 1. 158
2. 161
3. 173
4. 164

Key : (2) 161

Q.13 Let $|z_1 - 8 - 2i| \leq 1$ and $|z_2 - 2 + 6i| \leq 2$, $z_1, z_2 \in \mathbb{C}$. Then the minimum value of $|z_1 - z_2|$ is :

- Options 1. 10
2. 13
3. 7
4. 3

Key : (3) 7

Q.14 Consider an A. P. of positive integers, whose sum of the first three terms is 54 and the sum of the first twenty terms lies between 1600 and 1800. Then its 11th term is :

- Options 1. 108
2. 84
3. 122
4. 90

Key : (4) 90

Q.15 Let the line $x + y = 1$ meet the circle $x^2 + y^2 = 4$ at the points A and B. If the line perpendicular to AB and passing through the mid point of the chord AB intersects the circle at C and D, then the area of the quadrilateral AD BC is equal to :

- Options 1. $\sqrt{14}$
2. $3\sqrt{7}$
3. $2\sqrt{14}$
4. $5\sqrt{7}$

Key : (3) $2\sqrt{14}$

Q.16 Let $\vec{a} = 2\hat{i} - \hat{j} + 3\hat{k}$, $\vec{b} = 3\hat{i} - 5\hat{j} + \hat{k}$ and \vec{c} be a vector such that $\vec{a} \times \vec{c} = \vec{c} \times \vec{b}$ and

$$\left(\frac{\vec{a} + \vec{c}}{|\vec{a} + \vec{c}|}\right) \cdot \left(\frac{\vec{b} + \vec{c}}{|\vec{b} + \vec{c}|}\right) = 168. \text{ Then the maximum value of } |\vec{c}|^2 \text{ is :}$$

- Options 1. 77
2. 308
3. 154
4. 462

Key : (2) 308

Q.17 Let $L_1: \frac{x-1}{1} = \frac{y-2}{-1} = \frac{z-1}{2}$ and $L_2: \frac{x+1}{-1} = \frac{y-2}{2} = \frac{z}{1}$ be two lines.

Let L_3 be a line passing through the point (α, β, γ) and be perpendicular to both L_1 and L_2 . If L_3 intersects L_1 , then $|5\alpha - 11\beta - 8\gamma|$ equals :

- Options 1. 18
2. 16
3. 20
4. 25

Key : (4) 25

Q.18

The value of $\lim_{n \rightarrow \infty} \left(\sum_{k=1}^n \frac{k^3 + 6k^2 + 11k + 5}{(k+3)!} \right)$ is :

- Options 1. $4/3$
2. $5/3$
3. $7/3$
4. 2

Key : (2) $5/3$

Q.19

Let x_1, x_2, \dots, x_{10} be ten observations such that $\sum_{i=1}^{10} (x_i - 2) = 30$, $\sum_{i=1}^{10} (x_i - \beta)^2 = 98$, $\beta > 2$, and

their variance is $\frac{4}{5}$. If μ and σ^2 are respectively the mean and the variance of $2(x_1 - 1) + 4\beta$,

$2(x_2 - 1) + 4\beta, \dots, 2(x_{10} - 1) + 4\beta$, then $\frac{\beta\mu}{\sigma^2}$ is equal to :

- Options 1. 120
2. 110
3. 100
4. 90

Key : (3) 100

Q.20

The number of solutions of the equation $\left(\frac{9}{x} - \frac{9}{\sqrt{x}} + 2 \right) \left(\frac{2}{x} - \frac{7}{\sqrt{x}} + 3 \right) = 0$ is :

- Options 1. 1
2. 3
3. 4
4. 2

Key : (3) 4

SECTION-B

Q.21 Let $S = \{x : \cos^{-1}x = \pi + \sin^{-1}x + \sin^{-1}(2x+1)\}$. Then $\sum_{x \in S} (2x-1)^2$ is equal to _____.

Key: (5)

Q.22 Let $f: (0, \infty) \rightarrow \mathbb{R}$ be a twice differentiable function. If for some $a \neq 0$, $\int_0^1 f(\lambda x) d\lambda = af(x)$, $f(1) = 1$ and

$f(16) = \frac{1}{8}$, then $16 - f'\left(\frac{1}{16}\right)$ is equal to _____.

Key: (112)

Q.23 The number of 6-letter words, with or without meaning, that can be formed using the letters of the word MATHS such that any letter that appears in the word must appear at least twice, is _____.

Key: (1405)

Q.24 Let $S = \left\{m \in \mathbb{Z} : A^{m^2} + A^m = 3I - A^{-6}\right\}$, where $A = \begin{bmatrix} 2 & -1 \\ 1 & 0 \end{bmatrix}$. Then $n(S)$ is equal to _____.

Key: (2)

Q.25 Let $[t]$ be the greatest integer less than or equal to t . Then the least value of $p \in \mathbb{N}$ for which

$\lim_{x \rightarrow 0^+} \left(x \left(\left[\frac{1}{x} \right] + \left[\frac{2}{x} \right] + \dots + \left[\frac{p}{x} \right] \right) - x^2 \left(\left[\frac{1}{x^2} \right] + \left[\frac{2^2}{x^2} \right] + \dots + \left[\frac{p^2}{x^2} \right] \right) \right) \geq 1$ is equal to _____.

Key: (24)

PHYSICS

SECTION-A

Q.26 The expression given below shows the variation of velocity (v) with time (t),

$$v = At^2 + \frac{Bt}{C+t}. \text{ The dimension of } ABC \text{ is :}$$

Options 1. $[M^0L^2T^{-3}]$

2. $[M^0L^2T^{-2}]$

3. $[M^0L^1T^{-3}]$

4. $[M^0L^1T^{-2}]$

Key: (1) $[M^0 L^2 T^{-3}]$

Q.27 Consider I_1 and I_2 are the currents flowing simultaneously in two nearby coils 1 & 2, respectively. If L_1 = self inductance of coil 1, M_{12} = mutual inductance of coil 1 with respect to coil 2, then the value of induced emf in coil 1 will be

Options 1.

$$\varepsilon_1 = -L_1 \frac{dI_1}{dt} - M_{12} \frac{dI_2}{dt}$$

2.

$$\varepsilon_1 = -L_1 \frac{dI_1}{dt} + M_{12} \frac{dI_2}{dt}$$

3.

$$\varepsilon_1 = -L_1 \frac{dI_1}{dt} - M_{12} \frac{dI_1}{dt}$$

4.

$$\varepsilon_1 = -L_1 \frac{dI_2}{dt} - M_{12} \frac{dI_1}{dt}$$

Key : (1) $\varepsilon_1 = -L_1 \frac{dI_1}{dt} - M_{12} \frac{dI_2}{dt}$

Q.28 A coil of area A and N turns is rotating with angular velocity ω in a uniform magnetic field \vec{B} about an axis perpendicular to \vec{B} . Magnetic flux ϕ and induced emf ε across it, at an instant when \vec{B} is parallel to the plane of coil, are :

Options 1.

$$\phi = AB, \varepsilon = 0$$

2.

$$\phi = AB, \varepsilon = NAB\omega$$

3.

$$\phi = 0, \varepsilon = 0$$

4.

$$\phi = 0, \varepsilon = NAB\omega$$

Key : (4) $\phi = 0, \varepsilon = NAB\omega$

Q.29

The fractional compression $\left(\frac{\Delta V}{V}\right)$ of water at the depth of 2.5 km below the sea level is _____ %. Given, the Bulk modulus of water = $2 \times 10^9 \text{ N m}^{-2}$, density of water = 10^3 kg m^{-3} , acceleration due to gravity = $g = 10 \text{ m s}^{-2}$.

Options 1.

$$1.25$$

2.

$$1.75$$

3.

$$1.0$$

4.

$$1.5$$

Key : (1) 1.25

Q.30 Consider a long straight wire of a circular cross-section (radius a) carrying a steady current I . The current is uniformly distributed across this cross-section. The distances from the centre of the wire's cross-section at which the magnetic field [inside the wire, outside the wire] is half of the maximum possible magnetic field, any where due to the wire, will be

- Options 1. $[a/4, 3a/2]$
2. $[a/2, 2a]$
3. $[a/4, 2a]$
4. $[a/2, 3a]$

Key : (2) $[\frac{a}{2}, 2a]$

Q.31 A body of mass ' m ' connected to a massless and unstretchable string goes in verticle circle of radius ' R ' under gravity g . The other end of the string is fixed at the center of circle. If velocity at top of circular path is $n\sqrt{gR}$, where, $n \geq 1$, then ratio of kinetic energy of the body at bottom to that at top of the circle is

- Options 1. $\frac{n+4}{n}$
2. $\frac{n^2}{n^2+4}$
3. $\frac{n}{n+4}$
4. $\frac{n^2+4}{n^2}$

Key : (4) $\frac{n^2+4}{n^2}$

Q.32 The workdone in an adiabatic change in an ideal gas depends upon only :

- Options 1. change in its specific heat
2. change in its pressure
3. change in its volume
4. change in its temperature

Key : (4) change in its temperature

- Q.33 At the interface between two materials having refractive indices n_1 and n_2 , the critical angle for reflection of an em wave is θ_{1C} . The n_2 material is replaced by another material having refractive index n_3 such that the critical angle at the interface between n_1 and n_3 materials is θ_{2C} . If $n_3 > n_2 > n_1$; $\frac{n_2}{n_3} = \frac{2}{5}$ and $\sin\theta_{2C} - \sin\theta_{1C} = \frac{1}{2}$, then θ_{1C} is

Options 1.

1. $\sin^{-1}\left(\frac{5}{6n_1}\right)$

2.

2. $\sin^{-1}\left(\frac{1}{3n_1}\right)$

3.

3. $\sin^{-1}\left(\frac{1}{6n_1}\right)$

4.

4. $\sin^{-1}\left(\frac{2}{3n_1}\right)$

Key : (BONUS)

- Q.34 Given below are two statements : one is labelled as **Assertion (A)** and the other is labelled as **Reason (R)**.

Assertion (A) : Time period of a simple pendulum is longer at the top of a mountain than that at the base of the mountain.

Reason (R) : Time period of a simple pendulum decreases with increasing value of acceleration due to gravity and vice-versa.

In the light of the above statements, choose the **most appropriate** answer from the options given below :

- Options 1. (A) is false but (R) is true

2.

Both (A) and (R) are true and (R) is the correct explanation of (A)

3.

Both (A) and (R) are true but (R) is **not** the correct explanation of (A)

4.

(A) is true but (R) is false

Key : (2) Both (A) and (R) are true and (R) is the correct explanation of (A)

Q.35 Given below are two statements : one is labelled as **Assertion (A)** and the other is labelled as **Reason (R)**.

Assertion (A) : Emission of electrons in photoelectric effect can be suppressed by applying a sufficiently negative electron potential to the photoemissive substance.

Reason (R) : A negative electric potential, which stops the emission of electrons from the surface of a photoemissive substance, varies linearly with frequency of incident radiation.

In the light of the above statements, choose the **most appropriate answer** from the options given below :

Options 1. **(A)** is false but **(R)** is true

2.

Both **(A)** and **(R)** are true but **(R)** is **not** the correct explanation of **(A)**

3.

Both **(A)** and **(R)** are true and **(R)** is the correct explanation of **(A)**

4.

(A) is true but **(R)** is false

Key : (2) Both **(A)** and **(R)** are true but **(R)** is not the correct explanation of **(A)**

Q.36 An electric dipole of mass m , charge q , and length l is placed in a uniform electric field $\vec{E} = E_0 \hat{i}$. When the dipole is rotated slightly from its equilibrium position and released, the time period of its oscillations will be :

Options 1.

$$\frac{1}{2\pi} \sqrt{\frac{2ml}{qE_0}}$$

2.

$$\frac{1}{2\pi} \sqrt{\frac{ml}{2qE_0}}$$

3.

$$2\pi \sqrt{\frac{ml}{2qE_0}}$$

4.

$$2\pi \sqrt{\frac{ml}{qE_0}}$$

Key : (3) $2\pi \sqrt{\frac{ml}{2qE_0}}$

Q.37 Given below are two statements : one is labelled as **Assertion (A)** and the other is labelled as **Reason (R)**.

Assertion (A) : Electromagnetic waves carry energy but not momentum.

Reason (R) : Mass of a photon is zero.

In the light of the above statements, choose the **most appropriate answer** from the options given below :

Options 1. **(A)** is true but **(R)** is false

2.

Both **(A)** and **(R)** are true and **(R)** is the correct explanation of **(A)**

3.

Both **(A)** and **(R)** are true but **(R)** is **not** the correct explanation of **(A)**

4.

(A) is false but **(R)** is true

Key : (4) **(A)** is false but **(R)** true

Q.38 Match List - I with List - II.

List - I	List - II
(A) Electric field inside (distance $r > 0$ from center) of a uniformly charged spherical shell with surface charge density σ , and radius R .	(I) σ/ϵ_0
(B) Electric field at distance $r > 0$ from a uniformly charged infinite plane sheet with surface charge density σ .	(II) $\sigma/2\epsilon_0$
(C) Electric field outside (distance $r > 0$ from center) of a uniformly charged spherical shell with surface charge density σ , and radius R .	(III) 0
(D) Electric field between 2 oppositely charged infinite plane parallel sheets with uniform surface charge density σ .	(IV) $\frac{\sigma}{\epsilon_0 r^2}$

Choose the **correct answer** from the options given below :

Options 1. (A)-(IV), (B)-(I), (C)-(III), (D)-(II)

2. (A)-(IV), (B)-(II), (C)-(III), (D)-(I)

3. (A)-(II), (B)-(I), (C)-(IV), (D)-(III)

4. (A)-(III), (B)-(II), (C)-(IV), (D)-(I)

Key : (4) **(A)** - (III) **(B)** - (II) **(C)** - (IV) **(D)** - (I)

- Q.39 As shown below, bob A of a pendulum having massless string of length 'R' is released from 60° to the vertical. It hits another bob B of half the mass that is at rest on a frictionless table in the center. Assuming elastic collision, the magnitude of the velocity of bob A after the collision will be (take g as acceleration due to gravity.)

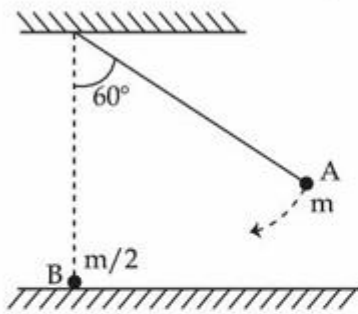

Options 1.

1. $\frac{1}{3}\sqrt{Rg}$

2.

2. $\frac{2}{3}\sqrt{Rg}$

3.

3. $\frac{4}{3}\sqrt{Rg}$

4.

4. \sqrt{Rg}

Key : (1) $\frac{1}{3}\sqrt{Rg}$

- Q.40 The pair of physical quantities not having same dimensions is :

Options 1.

1. Surface tension and impulse

2.

2. Pressure and Young's modulus

3.

3. Torque and energy

4.

4. Angular momentum and Planck's constant

Key : (1) Surface tension and impulse

Q.41 If λ and K are de Broglie wavelength and kinetic energy, respectively, of a particle with constant mass. The correct graphical representation for the particle will be

Options 1.

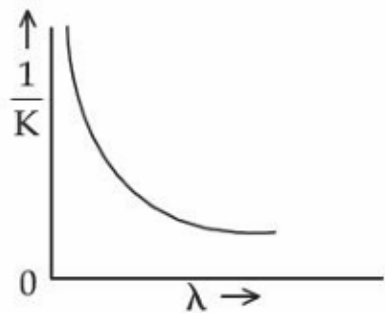

2.

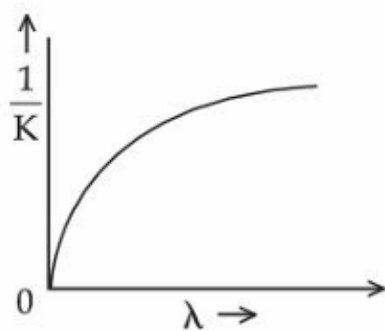

3.

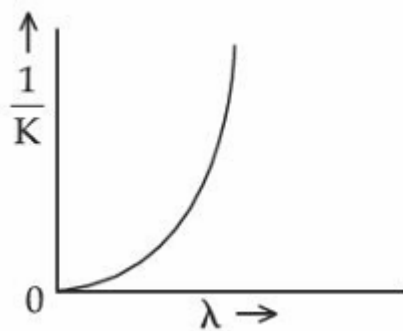

4.

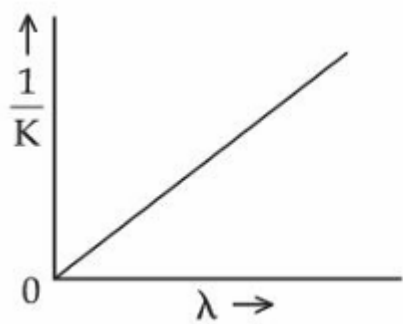

Key : (3)

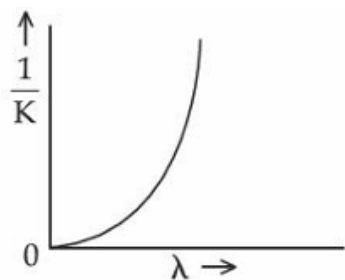

Q.42 Given below are two statements : one is labelled as **Assertion (A)** and the other is labelled as **Reason (R)**.

Assertion (A) : Choke coil is simply a coil having a large inductance but a small resistance. Choke coils are used with fluorescent mercury-tube fittings. If household electric power is directly connected to a mercury tube, the tube will be damaged.

Reason (R) : By using the choke coil, the voltage across the tube is reduced by a factor $\left(\frac{R}{\sqrt{R^2 + \omega^2 L^2}}\right)$, where ω is frequency of the supply across resistor R and inductor L. If the choke coil were not used, the voltage across the resistor would be the same as the applied voltage.

In the light of the above statements, choose the **most appropriate answer** from the options given below :

Options 1. **(A)** is false but **(R)** is true

2. **(A)** is true but **(R)** is false

3.

Both **(A)** and **(R)** are true and **(R)** is the correct explanation of **(A)**

4.

Both **(A)** and **(R)** are true but **(R)** is **not** the correct explanation of **(A)**

Key : (3) Both **(A)** and **(R)** are true and **(R)** is the correct explanation of **(A)**

Q.43

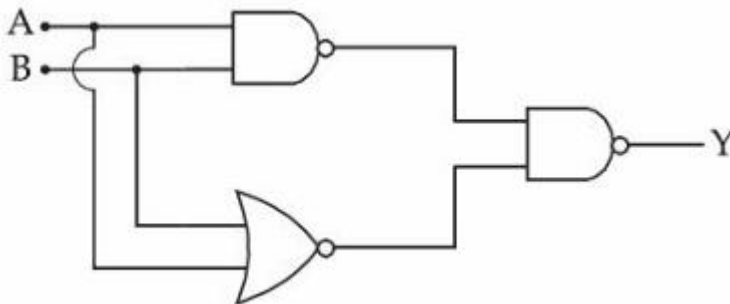

For the circuit shown above, equivalent GATE is :

Options 1. AND gate

2. OR gate

3. NAND gate

4. NOT gate

Key : (2) OR gate

Q.44 Let u and v be the distances of the object and the image from a lens of focal length f . The correct graphical representation of u and v for a convex lens when $|u| > f$, is

Options 1.

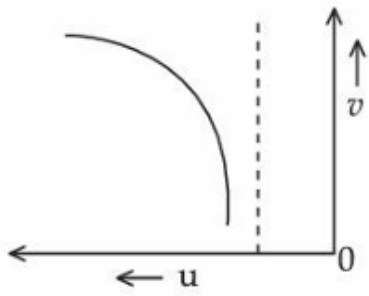

2.

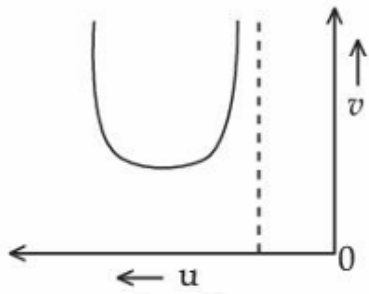

3.

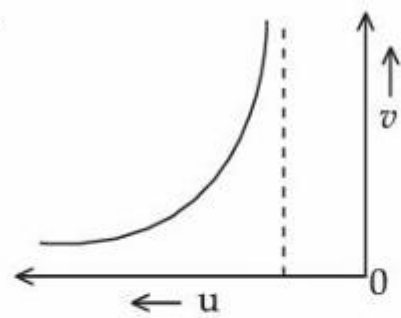

4.

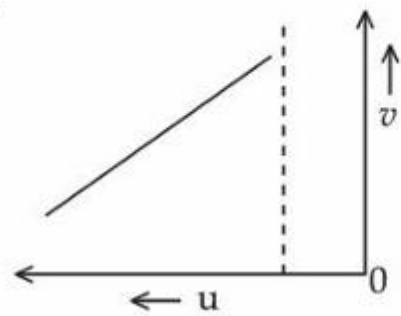

Key : (3)

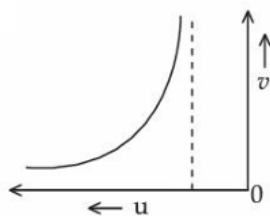

Q.45 Two projectiles are fired with same initial speed from same point on ground at angles of $(45^\circ - \alpha)$ and $(45^\circ + \alpha)$, respectively, with the horizontal direction. The ratio of their maximum heights attained is :

Options 1.

$$\frac{1 - \sin 2\alpha}{1 + \sin 2\alpha}$$

2.

$$\frac{1 + \sin \alpha}{1 - \sin \alpha}$$

3.

$$\frac{1 - \tan \alpha}{1 + \tan \alpha}$$

4.

$$\frac{1 + \sin 2\alpha}{1 - \sin 2\alpha}$$

Key : (1) $\frac{1 - \sin 2\alpha}{1 + \sin 2\alpha}$

SECTION-B

Q.46 A container of fixed volume contains a gas at 27°C . To double the pressure of the gas, the temperature of gas should be raised to _____ $^\circ \text{C}$.

Key : (327 $^\circ$)

Q.47 Two light beams fall on a transparent material block at point 1 and 2 with angle θ_1 and θ_2 , respectively, as shown in figure. After refraction, the beams intersect at point 3 which is exactly on the interface at other end of the block. Given : the distance between 1 and 2,

$d = 4\sqrt{3}$ cm and $\theta_1 = \theta_2 = \cos^{-1}\left(\frac{n_2}{2n_1}\right)$, where refractive index of the block $n_2 >$ refractive

index of the outside medium n_1 , then the thickness of the block is _____ cm.

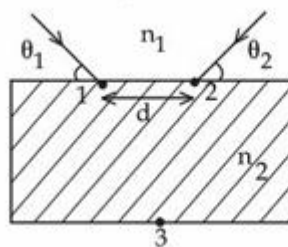

Key : (6)

Q.48 In a hydraulic lift, the surface area of the input piston is 6 cm^2 and that of the output piston is 1500 cm^2 . If 100 N force is applied to the input piston to raise the output piston by 20 cm , then the work done is _____ kJ.

Key : (5)

Q.49 The maximum speed of a boat in still water is 27 km/h . Now this boat is moving downstream in a river flowing at 9 km/h . A man in the boat throws a ball vertically upwards with speed of 10 m/s . Range of the ball as observed by an observer at rest on the river bank, is _____ cm. (Take $g = 10 \text{ m/s}^2$)

Key : (2000)

Q.50 The coordinates of a particle with respect to origin in a given reference frame is (1, 1, 1) meters. If a force of $\vec{F} = \hat{i} - \hat{j} + \hat{k}$ acts on the particle, then the magnitude of torque (with respect to origin) in z-direction is _____.

Key : (2)

CHEMISTRY

SECTION-A

Q.51 An element 'E' has the ionisation enthalpy value of 374 kJ mol^{-1} . 'E' reacts with elements A, B, C and D with electron gain enthalpy values of -328 , -349 , -325 and -295 kJ mol^{-1} , respectively. The correct order of the products EA, EB, EC and ED in terms of ionic character is :

- Options
1. $ED > EC > EB > EA$
 2. $EA > EB > EC > ED$
 3. $EB > EA > EC > ED$
 4. $ED > EC > EA > EB$

Key : (3) $EB > EA > EC > ED$

Q.52 1.24 g of AX_2 (molar mass 124 g mol^{-1}) is dissolved in 1 kg of water to form a solution with boiling point of 100.0156°C , while 25.4 g of AY_2 (molar mass 250 g mol^{-1}) in 2 kg of water constitutes a solution with a boiling point of 100.0260°C .

$$K_b(\text{H}_2\text{O}) = 0.52 \text{ K kg mol}^{-1}$$

Which of the following is correct ?

- Options
1. AX_2 and AY_2 (both) are fully ionised.
 2. AX_2 is fully ionised while AY_2 is completely unionised.
 3. AX_2 is completely unionised while AY_2 is fully ionised.
 4. AX_2 and AY_2 (both) are completely unionised.

Key : (2) AX_2 is fully ionised while AY_2 is completely unionised

Q.53 Given below are two statements :

Statement (I) : The radii of isoelectronic species increases in the order.

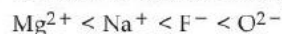

Statement (II) : The magnitude of electron gain enthalpy of halogen decreases in the order.

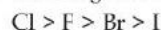

In the light of the above statements, choose the most appropriate answer from the options given below :

- Options
1. Both Statement I and Statement II are incorrect
 2. Statement I is correct but Statement II is incorrect
 3. Both Statement I and Statement II are correct
 4. Statement I is incorrect but Statement II is correct

Key : (3) Both statement I and statement II are correct

Q.54 Total number of nucleophiles from the following is :

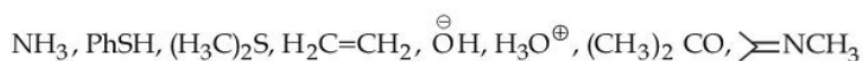

- Options
- 4
 - 5
 - 6
 - 7

Key : (2) 5

Q.55 Match List - I with List - II.

List - I (Complex)	List - II (Hybridisation & Magnetic characters)
(A) $[\text{MnBr}_4]^{2-}$	(I) d^2sp^3 & diamagnetic
(B) $[\text{FeF}_6]^{3-}$	(II) sp^3d^2 & paramagnetic
(C) $[\text{Co}(\text{C}_2\text{O}_4)_3]^{3-}$	(III) sp^3 & diamagnetic
(D) $[\text{Ni}(\text{CO})_4]$	(IV) sp^3 & paramagnetic

Choose the correct answer from the options given below :

- Options
- (A)-(IV), (B)-(I), (C)-(II), (D)-(III)
 - (A)-(III), (B)-(I), (C)-(II), (D)-(IV)
 - (A)-(III), (B)-(II), (C)-(I), (D)-(IV)
 - (A)-(IV), (B)-(II), (C)-(I), (D)-(III)

Key : (4) (A)-(IV), (B)-(II), (C)-(I), (D)-(III)

Q.56 Match List - I with List - II.

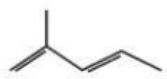
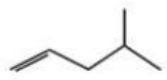
List - I (Structure)	List - II (IUPAC Name)
(A) $\text{H}_3\text{C}-\text{CH}_2-\underset{\text{C}_2\text{H}_5}{\text{CH}}-\text{CH}_2-\underset{\text{CH}_3}{\text{CH}}-\text{C}_2\text{H}_5$	(I) 4-Methylpent-1-ene
(B) $(\text{CH}_3)_2\text{C}(\text{C}_3\text{H}_7)_2$	(II) 3-Ethyl-5-methylheptane
(C) 	(III) 4,4-Dimethylheptane
(D) 	(IV) 2-Methyl-1,3-pentadiene

Choose the correct answer from the options given below :

- Options
- (A)-(III), (B)-(II), (C)-(I), (D)-(IV)
 - (A)-(III), (B)-(II), (C)-(IV), (D)-(I)
 - (A)-(II), (B)-(III), (C)-(I), (D)-(IV)
 - (A)-(II), (B)-(III), (C)-(IV), (D)-(I)

Key : (4) (A)-(II), (B)-(III), (C)-(IV), (D)-(I)

Q.57 500 J of energy is transferred as heat to 0.5 mol of Argon gas at 298 K and 1.00 atm. The final temperature and the change in internal energy respectively are :
Given : $R = 8.3 \text{ J K}^{-1} \text{ mol}^{-1}$

- Options**
1. 348 K and 300 J
 2. 368 K and 500 J
 3. 378 K and 300 J
 4. 378 K and 500 J

Key : (1) 348 K and 300 J

Q.58 The molar conductivity of a weak electrolyte when plotted against the square root of its concentration, which of the following is expected to be observed ?

- Options**
1. Molar conductivity decreases sharply with increase in concentration.
 2. Molar conductivity increases sharply with increase in concentration.
 3. A small increase in molar conductivity is observed at infinite dilution.
 4. A small decrease in molar conductivity is observed at infinite dilution.

Key : (1) Molar conductivity decreases sharply with increase in concentration

Q.59 The correct increasing order of stability of the complexes based on Δ_o value is :

I. $[\text{Mn}(\text{CN})_6]^{3-}$ II. $[\text{Co}(\text{CN})_6]^{4-}$ III. $[\text{Fe}(\text{CN})_6]^{4-}$ IV. $[\text{Fe}(\text{CN})_6]^{3-}$

- Options**
1. III < II < IV < I
 2. IV < III < II < I
 3. II < III < I < IV
 4. I < II < IV < III

Key : (4) I < II < IV < III

Q.60 The correct option with order of melting points of the pairs (Mn, Fe), (Tc, Ru) and (Re, Os) is :

- Options**
1. Fe < Mn, Ru < Tc and Os < Re
 2. Mn < Fe, Tc < Ru and Re < Os
 3. Mn < Fe, Tc < Ru and Os < Re
 4. Fe < Mn, Ru < Tc and Re < Os

Key : (3) Mn < Fe, Tc < Ru and Os < Re

Q.61 The reaction $A_2 + B_2 \rightarrow 2AB$ follows the mechanism

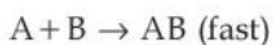
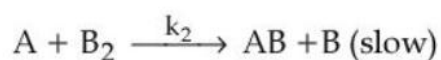
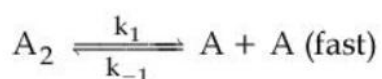

The overall order of the reaction is :

- Options
1. 2.5
 2. 2
 3. 1.5
 4. 3

Key : (3) 1.5

Q.62 Match List - I with List - II.

List - I
(Carbohydrate)

- (A) Amylose
(B) Cellulose
(C) Glycogen
(D) Amylopectin

List - II
(Linkage Source)

- (I) β -C₁-C_{4'} plant
(II) α -C₁-C_{4'} animal
(III) α -C₁-C_{4'} α -C₁-C_{6'} plant
(IV) α -C₁-C_{4'} plant

Choose the **correct** answer from the options given below :

- Options
1. (A)-(IV), (B)-(I), (C)-(II), (D)-(III)
 2. (A)-(III), (B)-(II), (C)-(I), (D)-(IV)
 3. (A)-(IV), (B)-(I), (C)-(III), (D)-(II)
 4. (A)-(II), (B)-(III), (C)-(I), (D)-(IV)

Key : (1) (A)-(IV), (B)-(I), (C)-(II), (D)-(III)

Q.63 In the following substitution reaction :

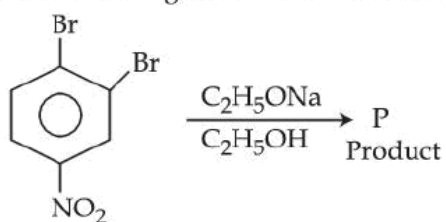

product 'P' formed is :

Options 1.

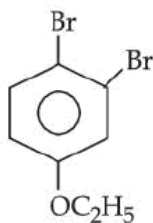

2.

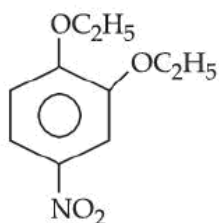

3.

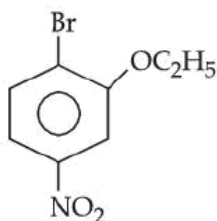

4.

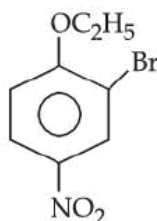

Key :

(4)

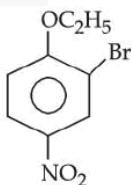

Q.64 Choose the **correct** statements.

- (A) Weight of a substance is the amount of matter present in it.
- (B) Mass is the force exerted by gravity on an object.
- (C) Volume is the amount of space occupied by a substance.
- (D) Temperatures below 0°C are possible in Celsius scale, but in Kelvin scale negative temperature is not possible.
- (E) Precision refers to the closeness of various measurements for the same quantity.

Choose the **correct** answer from the options given below :

Options 1.

(A), (D) and (E) Only

2.

(A), (B) and (C) Only

3.

(B), (C) and (D) Only

4.

(C), (D) and (E) Only

Key : (4) (C), (D) and (E) only

Q.65

At temperature T, compound $AB_{2(g)}$ dissociates as $AB_{2(g)} \rightleftharpoons AB_{(g)} + \frac{1}{2} B_{2(g)}$ having degree of dissociation x (small compared to unity). The correct expression for x in terms of K_p and p is

Options 1.

$$1. \sqrt[3]{\frac{2K_p}{p}}$$

2.

$$\sqrt[4]{\frac{2K_p}{p}}$$

3.

$$\sqrt[3]{\frac{2K_p^2}{p}}$$

4.

$$\sqrt{K_p}$$

Key : (3) $\sqrt[3]{\frac{2K_p^2}{p}}$

Q.66

For a $Mg | Mg^{2+}(aq) || Ag^+(aq) | Ag$ the correct Nernst Equation is :

Options 1.

$$1. E_{\text{cell}} = E_{\text{cell}}^{\circ} - \frac{RT}{2F} \ln \frac{[Ag^+]^2}{[Mg^{2+}]}$$

2.

$$2. E_{\text{cell}} = E_{\text{cell}}^{\circ} - \frac{RT}{2F} \ln \frac{[Ag^+]}{[Mg^{2+}]}$$

3.

$$3. E_{\text{cell}} = E_{\text{cell}}^{\circ} - \frac{RT}{2F} \ln \frac{[Mg^{2+}]}{[Ag^+]}$$

4.

$$4. E_{\text{cell}} = E_{\text{cell}}^{\circ} + \frac{RT}{2F} \ln \frac{[Ag^+]^2}{[Mg^{2+}]}$$

Key : (4) $E_{\text{cell}} = E_{\text{cell}}^{\circ} + \frac{RT}{2F} \ln \frac{[Ag^+]^2}{[Mg^{2+}]}$

Q.67 The standard reduction potential values of some of the p-block ions are given below. Predict the one with the strongest oxidising capacity.

Options 1.

$$E_{\text{Pb}^{4+}/\text{Pb}^{2+}}^{\ominus} = +1.67 \text{ V}$$

2.

$$E_{\text{Ti}^{3+}/\text{Ti}}^{\ominus} = +1.26 \text{ V}$$

3.

$$E_{\text{Sn}^{4+}/\text{Sn}^{2+}}^{\ominus} = +1.15 \text{ V}$$

4.

$$E_{\text{Al}^{3+}/\text{Al}}^{\ominus} = -1.66 \text{ V}$$

Key : (1) $E_{\text{Pb}^{4+}/\text{Pb}^{2+}}^{\ominus} = +1.67 \text{ V}$

Q.68 The steam volatile compounds among the following are :

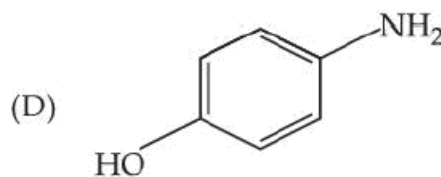
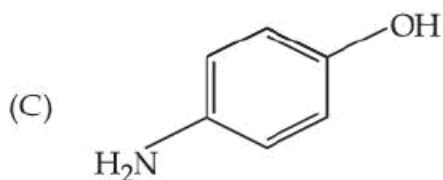
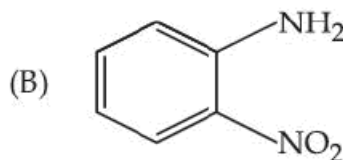
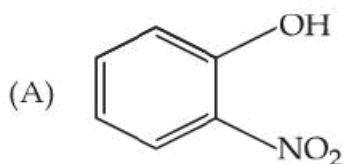

Choose the **correct** answer from the options given below :

Options 1. (A), (B) and (C) Only

2. (A) and (C) Only

3. (A) and (B) Only

4. (B) and (D) Only

Key : (3) (A) and (B) only

Q.69 If a_0 is denoted as the Bohr radius of hydrogen atom, then what is the de-Broglie wavelength (λ) of the electron present in the second orbit of hydrogen atom ? [n : any integer]

Options 1.

$$\frac{4n}{\pi a_0}$$

2. $\frac{8\pi a_0}{n}$

3. $\frac{2a_0}{n\pi}$

4. $\frac{4\pi a_0}{n}$

Key : (2) $\frac{8\pi a_0}{n}$

Q.70 The product (P) formed in the following reaction is :

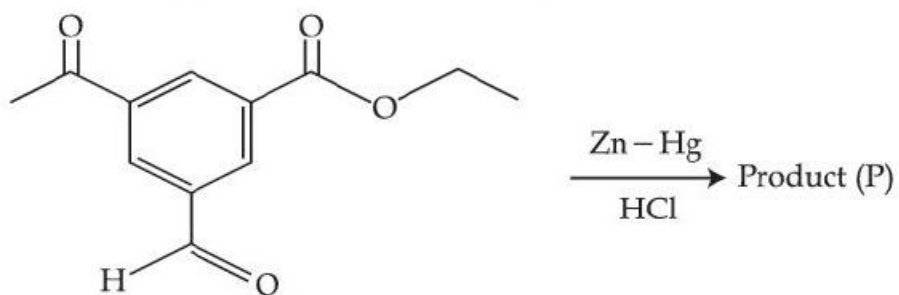

Options 1.

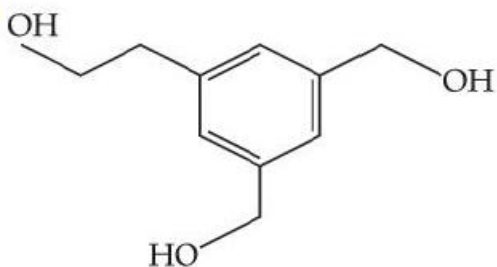

2.

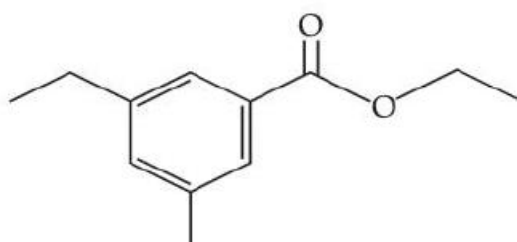

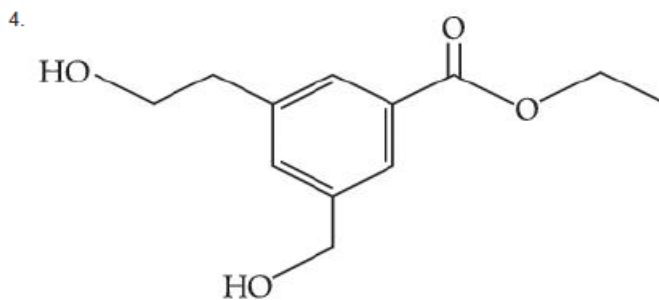
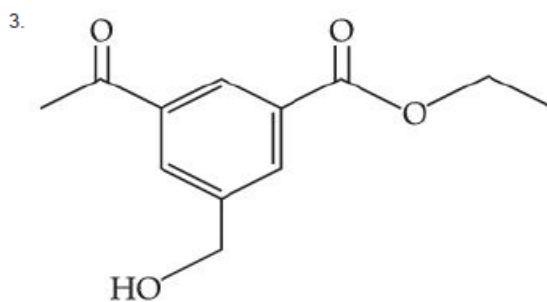

Key: (2)

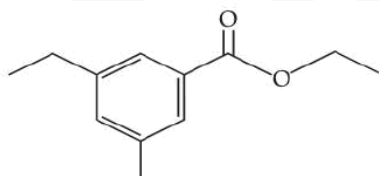

SECTION-B

71. If A_2B is 30% ionised in an aqueous solution, then the value of van't Hoff factor (i) is _____ $\times 10^{-1}$.

Key: (16)

72. Given below are some nitrogen containing compounds

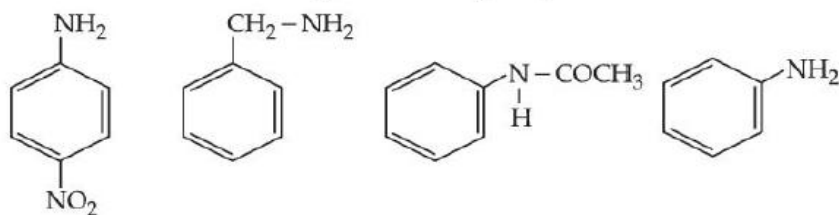

Each of them is treated with HCl separately. 1.0 g of the most basic compound will consume _____ mg of HCl.

(Given molar mass in g mol^{-1} C : 12, H : 1, O : 16, Cl : 35.5)

Key: (341)

73. The sum of sigma (σ) and pi (π) bonds in Hex-1,3-dien-5-yne is _____.

Key: (15)

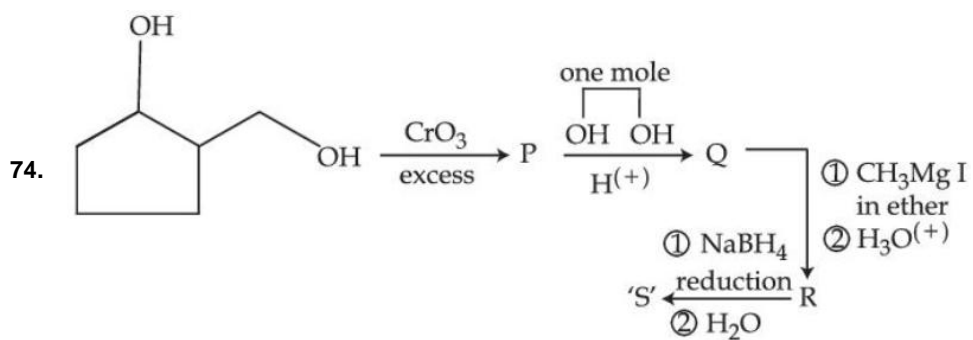

0.1 mole of compound 'S' will weigh _____ g.
 (Given molar mass in g mol^{-1} C : 12, H : 1, O : 16)

Key: (13)

75. The molar mass of the water insoluble product formed from the fusion of chromite ore (FeCr_2O_4) with Na_2CO_3 in presence of O_2 is _____ g mol^{-1} .

Key: (160)